



MAESTRO SERIES 800, 1000, 1200



A range of SUBMERGED Arc Welding Equipment to suit a wide range of applications

SALIENT FEATURES

- Choice of Boom mounted or Tractor mounted Welding head models offered with Diode or Thyristorized Power Source
- Boom mounted head comes with a choice of manual, semi – motorized and fully motorized cross slides
- Programmed sequential operations of Power Source, Wire feed and carriage through built- in solid state circuitry
- **Twin Wire Attachment** : Twin Wire Attachment is available for the Tractor as well as boom mounted welding heads. The arrangement consists of one set of each of wire drive roll and nozzle for 2 and 2.5 mm size wire to feed two wires in tandem and increase

the deposition rate substantially. These arrangements is ideal for applications like cladding of hard surfaces as well as for filing weld metal in extra large size preparation grooves. Twin 2.5 mm wires can deliver up to 20% higher deposition rates than a single 5 mm wire at the same welding current and arc voltage parameters.

- **Fillet Welding Attachment** : To enhance the usability of SAW Outfits, a Fillet Welding attachment can be provided to increase shop-floor productivity.
- **Spot Light Projector** : This facility is especially useful for welding operations inside cylindrical jobs where a light source is required to examine the seam

The Welder - friendly tractor or boom mounted welding head with Diode / Thyristorized Power sources perfectly match; Adopted to local conditions; offering a range of models to suits every budget and need

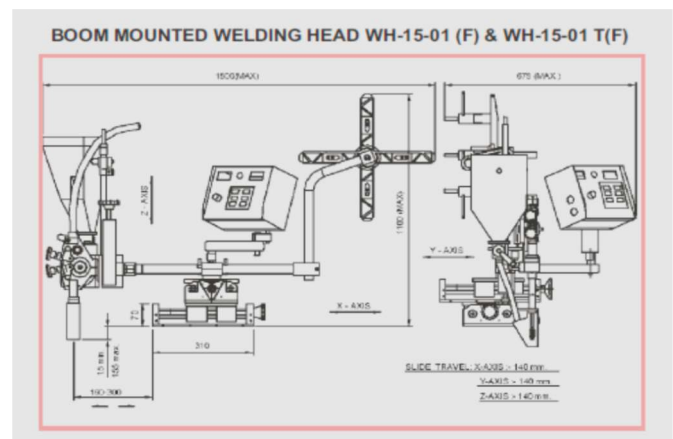
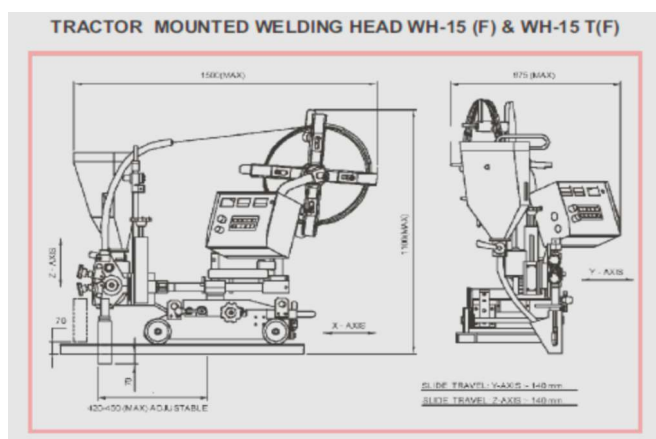

MAESTRO SERIES 800, 1000, 1200

A range of SUBMERGED Arc Welding Equipment to suit a wide range of applications



TECHNICAL SPECIFICATIONS DOIDE BASED SYSTEMS



Power Source	Unit	PS 800 (F)	PS 1000 (F)	PS 1200 (F)
Input				
Input Supply:				
Voltage	Volts, AC	415	415	415
Phase	No	3	3	3
Frequency	Hz	50	50	50
Input Kva @ 100% Duty Cycle	KVA	37	45	54
Recommended Switch Fuse Rating	Amps, AC	TP-60	TP-80	TP-100
Output				
Static Characteristics	Type	CV	CV	CV
Open Circuit Voltage Range (max. With IPT)	Volts, DC	35-63	35-63	35-63
Open Circuit Voltage Range (Actual)		29-54	29-54	29-54
Welding Voltage		21.15-44	24-44	24-44
Welding Current Range	Amps, DC	150-800	200-100	200-1200
Welding current @ 60% duty cycle		800	100	1200
Welding current @ 100% duty cycle		650	800	1000
General				
Insulation	Class	H	H	H
Cooling	Type	Forced Air	Forced Air	Forced Air
Dimensions L x W x H	mm	1225x800x900	1225x800x900	1225x800x900
Weight (Approx)	Kg	350	365	390

TECHNICAL SPECIFICATIONS THYRISTOR BASED SYSTEMS



Power Source	Unit	PS 800 T(F)	PS 1000 T(F)	PS 1200 T(F)
Input				
Input Supply:				
Voltage	Volts, AC	415	415	415
Phase	No	3	3	3
Frequency	Hz	50	50	50
Input Kva @ 100% Duty Cycle	KVA	44	50	63
Recommended Switch Fuse Rating	Amps, AC	TP-70	TP-80	TP-100
Output				
Static Characteristics	Type	CV	CV	CV
Open Circuit Voltage Range (max.)	Volts, DC	62	62	62
Open Circuit Voltage Range		150-800	200-1000	200-1200
Welding current @ 60% duty cycle	Amps, DC	800	100	1200
Welding current @ 100% duty cycle		650	800	1000

MAESTRO SERIES 800, 1000, 1200



A range of SUBMERGED Arc Welding Equipment to suit a wide range of applications

Cont.

General				
Insulation	Class	H	H	H
Cooling	Type	Forced Air	Forced Air	Forced Air
Dimensions L x W x H	mm	1225x800x1060	1225x800x1060	1225x800x1060
Weight (Approx)	Kg	350	365	390

ORDERING INFORMATION OPTIONAL ACCESSORIES

Description	Product Code
Set Of Welding Cables SAC 800, For PS 800 (F), 800 T (F)	S10.36.011.0005
Set Of Welding Cables SAC 1000, For PS 800 (F), 1000 T (F)	S10.36.011.0006
Set Of Welding Cables SAC 1200, For PS 800 (F), 1200 T (F)	S10.36.011.0004
Description	Product Code
WAS : Set Of Welders Accessories - All Models	S10.36.041.0001
SLP: Spotlight Projector - All Models	S10.36.031.0001
FWA: Fillet Welding Attachment - All Models	S10.36.021.0001
TWA: Twin Wire Attachment (2 And 2.5 Mm) - All Models	S10.36.021.0003

TECHNICAL SPECIFICATIONS - WELDING HEADS

Saw Head	Unit	WH -15(F)	WH -15-01(F)	WH -15-02(F)	WH -15-03(F)
Max. Welding Current @ 60% Duty Cycle	Amps, DC	1500	1500	1500	1500
Max. Welding Current @ 60% Duty Cycle		1250	1250	1250	1250
Recommended Power Source		PS 800 (F) / PS 1000 (F) / PS 1200 (F)			
Recommended Wire Diameter Single Wire	mm	2, 2.5, 3.2 For 800 (F); 2, 2.5, 3.2, 4.5 For 1000 (F) & 1200 (F)			
Recommended Wire Diameter Twin Wire		2, 2.5 (Optional)			
Speed Range Wire Feed	M / Min.	0.5-4	0.5-4	0.5-4	0.5-4
Speed Range Carriage		0.1-1.5	NA	NA	NA
Input To Control Unit	Volts, AC	42 V, 1 PH, 50 Hz From Power Source			
Range Of Adjustment					
Vertical (Z)	mm	140 (Manual)	140 (Manual)	100 (Motorized)	100 (Motorized)
Horizontal (X)-Transverse To Travel Direction		140 (Manual)	140 (Manual)	100 (Motorized)	100 (Motorized)
Horizontal (Y)-In Direction Of Travel		-	140 (Manual)	140 (Manual)	100 (Motorized)
Maximum Swivel					
Transverse To Head Travel	Degree	45			
Parallel To Head Travel		30			
Horizontal Swing		270			
Standard Bore For Spool	mm	285 - 315 (Adjustable)			
Weight Of Spool (max.)	Kg	25			
Flux Hopper Capacity (max.)	Kg/Ltrs	10/7			
Dimensions (L X W X H)	mm	1500x1030x580	1500x1030x580	1500x1030x600	1500x1030x600
Weight (without Flux And Wire)	Kg	80	80	110	110

Cont.

MAESTRO SERIES 800, 1000, 1200



A range of SUBMERGED Arc Welding Equipment to suit a wide range of applications

- **Warranty:** One year from the date of commissioning. ADOR WELDING LIMITED warrants that all new equipment sold from Plant/Area Offices / Authorised Distributors are free from defects in materials and workmanship and will perform in full accordance with applicable specifications.
- In view of continuous development, ADOR WELDING LIMITED reserves the right to modify/change the design and /or the specifications without any prior notice.
- Backed by dedicated customer care package.