

PASSION FOR WELDING SINCE 1951



(Formerly Advani-Oerlikon Ltd.)

e-weldone

Issue | June 2020



A Guide on Smokeless Flaring: Air/Steam Assisted and High Pressure Flaring

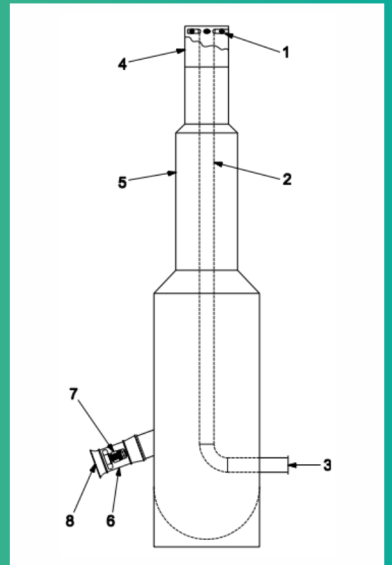
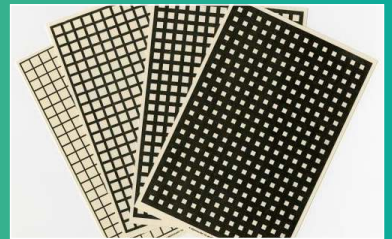

GUIDE ON SMOKELESS FLARING

Published in International Journal
of Engineering Applied Sciences
and Technology, 2020

follow us:



A Guide on Smokeless Flaring: Air/Steam Assisted and High Pressure Flaring

By Project Engineering Business, ADOR Welding Limited.



Abstract:

The flaring of some gases such as higher hydrocarbons produces smoke and need some medium to reduce or eliminate that. Air or steam assistance is often used to suppress that smoke and which create energy and turbulence in the system and promote even air distribution throughout the flames. The different other methods are also analyzed in this paper. This paper also discussed how to assess the degree of smokelessness which is categorized by air pollution board as acceptable. It is also assessed that the quantity of air required is approximately 1.2 times higher than that of steam and is more expensive as per installation point of view. The high pressure flaring can also achieve smokeless flaring and detailed overview of which is discussed in this paper.

Keywords— Smokeless, Flaring, High pressure flaring.

I. INTRODUCTION

During extraction process, large amount of excess gases are continuously flowing which needs a system to dispose them. Such disposal of combustible gases, vapors and liquids by burning is generally accomplished in flares. Flares are generally used to control environment pollution by burning waste hazardous gases, therefore, the burning of gases. The flaring must be smokeless in order to reduce pollution and is usually a fraction of maximum gas flows, but some environmentally sensitive areas require 100% smokeless. The need for smokeless burning has become essential and should be explicitly defined. Smoke consists of gas and small bits of solid material that are sent into the air when something burns and which happen when there is an incomplete combustion (not enough oxygen to burn the fuel completely).

Smokeless means to suppress the smoke formed while flaring using some techniques, which are based on the premise that smoke is the result of a fuel-rich condition and is eliminated by promoting uniform air distribution throughout

the flames [1]. To promote even air distribution throughout the flames, energy is required for creating turbulence and mixing assisted fluid in the flame so as to prevent smoke. This energy can be created in the form of pressure and velocity, or it can be exerted on the system through another medium, such as injecting high pressure steam, compressed air or low pressure blower air into gases as they exit the flare tip [1].

Fig.1. Ringlemann Scale opacity chart [2]

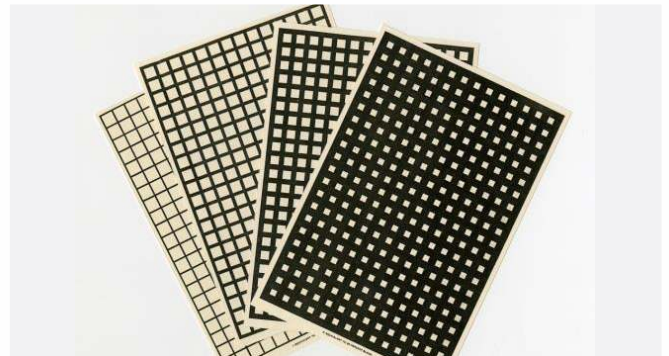

To assess the degree of smokelessness, Ringlemann scale is used. The Ringlemann scale is a scale for measuring the apparent density or opacity of smoke [2, 3]. The scale has 5 levels of density presented by a grid of black lines on a white surface, which if viewed from a distance, merge into known shades of grey. Shade 1 (Ringlemann 1) is slightly grey and is usually categorized by air pollution boards as acceptable. It corresponds to opacity of 20%. Shades 2, 3, 4 and 5 correspond to opacities of 40%, 60%, 80% and 100% (completely black) and are usually considered to be "black smoke" by air pollution boards of most countries [4].

Many state and countries regulation state the smokeless requirements in the form 'No operator shall allow the flare emissions to exceed 20% opacity or Ringlemann 1 for more than 5min any consecutive 2 hour period'. Other regulations may be different which depends on local regulatory authority.



A Guide on Smokeless Flaring: Air/Steam Assisted and High Pressure Flaring

By Project Engineering Business, ADOR Welding Limited.



Therefore, the smokeless operation is normally the overriding requirement while designing the flare system. Smoking tendency is a function of the gas calorific value and of the bonding structure of the hydrocarbons. The paraffinic series of hydrocarbons has the lowest tendency to produce smoke, whereas olefinic, diolefinic and aromatic series of hydrocarbons have a much higher tendency to produce smoke. Smokeless combustion is achieved by utilizing air, steam, pressure energy of flare gas or other means to create turbulence and entrain air within the flared gas steam.

II. RESULTS AND DISCUSSION

Steam-assisted flare:

Steam at high pressure is injected to the flare gas combustion zone. The steam assist equipment should not disrupt the basic flame stabilization mechanisms of the flare burner. The flame produced by a flare burner is a function of flare gas characteristics, the gas exit velocities and how the steam is injected. Generally, the velocity is 20-25 m/s for Low pressure (LP) and Medium pressure (MP) steam and 35-40 m/s for high pressure (HP) steam and which decide the turbulence rate of the relief gas exiting from the burner. Steam consumption for smokeless burning is a function of the flare gas composition, burner size and design, steam injector design and operating pressure and the environmental conditions. While steam injection helps in reducing smoke formation, it also adversely affects the combustion of relief gases with a high level of inert, and hence it requires the flare gas to be of high calorific values. This steam injection is done at the top of a flare burner by employing a steam ring which has a number of injection nozzles to initiate the turbulence efficiently. A properly designed upper steam ring can also act as a windshield to reduce adverse wind effects on the flame.

Steam consumption can be calculated on the basis of below formula:

$$\text{Steam quantity (kg/hr)} = \left(0.68 - \left(\frac{10.8}{MW} \right) \right) \times \text{Smokeless load}$$

Where,

MW = Molecular weight of flare gas

Smokeless load in kg/hr = As per Ringlemann scale (For e.g. Ringlemann 1 needs 20% of flare load as smokeless load.

Apart from employing upper steam ring, smokeless flaring at higher and lower rates can be achieved by injecting steam into the relief gas discharge from tubes located inside the flare burner barrel. These internal tubes are designed to act as air eductor which uses steam energy to pull combustion air into the flare gas and allow mixing with it. Greater access to combustion air enhances the maximum smokeless flaring rate, but at the same time it also increases the chance of clogging of burner due to condensation and freezing.

The suggested steam injection rates are shown in Table.1 [1]. These values provide only a general guideline as the quantity depends on several other parameters like tip design configuration, gas flow rate, gas composition, gas pressure and other factors.

Air-Assisted Flare:

High pressure air can also be used to prevent smoke formation when steam is not available. It is less effective and more expensive than steam. However, in some region where temperature is very low, air can be preferable, because of the plugging of tip due to freezing of steam. It can also be preferably used where there is shortage of water (e.g. desert areas) or where the flare gas reacts with steam.





A Guide on Smokeless Flaring: Air/Steam Assisted and High Pressure Flaring

By Project Engineering Business, ADOR Welding Limited.

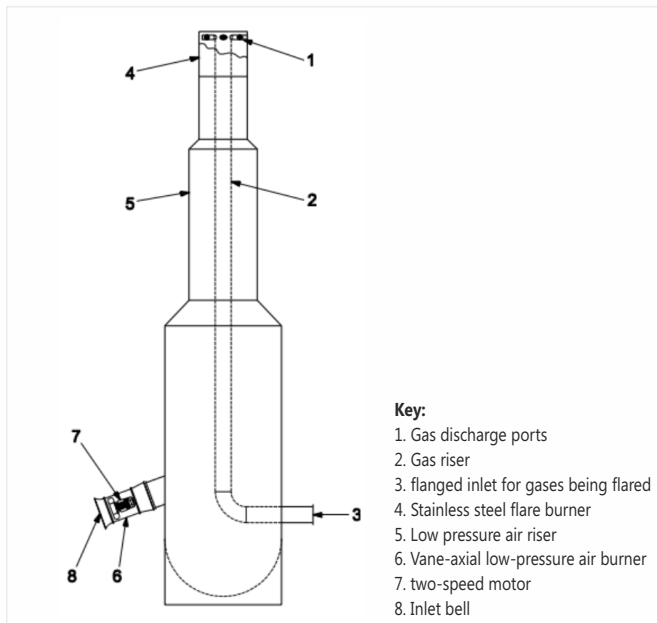

Fig.2. Air-assisted Flare [7]

The mass of air required is approximately 1.2 times the steam mass. This type of assistance is required generally where an existing flare is producing smoke and is required to suppress that smoke by some external assistance. Air-assisted flares generally consists of an air blower, air duct and an air manifold (acts as a gas distributor) around the tip. There is no need of any plant assistance as needed in steam, and hence can operate independently by just installing an air blower. The flame produced by an air-assisted flare burner is a function of the combined mixing energy of the relief-gas discharge and the forced airflow rate and velocity. Typically air blower delivers only a fraction of the flow rate of air required for stoichiometric smokeless combustion. This air fraction is used to promote mixing with the relief-gas discharge and to add momentum to the flare discharge to effectively entrain additional combustion air from the surrounding atmosphere.

Table.1. Steam rate required for smokeless flaring according to API 521.

Gases Being Flared	Approximate Steam Rate (kg of steam perkg of hydrocarbon gas)
Paraffins	
Ethane	0.1 to 0.15
Propane	0.25 to 0.3
Butane	0.3 to 0.35
Pentane+	0.4 to 0.45
Olefins	
Ethylene	0.4 to 0.5
Propylene	0.5 to 0.6
Butene	0.6 to 0.7
Diolefins	
Propadiene	0.7 to 0.8
Butadiene	0.9 to 1
Pentadiene	1.1 to 1.2
Acetylenes	
Acetylene	0.5 to 0.6
Aromatics	
Benzene	0.8 to 0.9
Toluene	0.85 to 0.95
Xylene	0.9 to 1





A Guide on Smokeless Flaring: Air/Steam Assisted and High Pressure Flaring

By Project Engineering Business, ADOR Welding Limited.

The flame produced by an air-assisted burner can be shaped by the use of the forced-draught air. The flame can be developed in an axial airflow manner to produce an erect, vertical flame. Alternatively, the forced air can be swirled to promote a rotational airflow that can produce a wider, shorter flame. The rate of smokeless burning and the flame characteristics are somewhat adjustable by the quantity of combustion air used and by its energy of discharge (to promote fuel-air mixing and flare-discharge momentum). The required air quantity depends on the C/H ratio where C stands for carbon and H for hydrogen in a hydrocarbon. When there is no hydrocarbon in the flare gas, the smoke tendency of flare is highly reduced and any type assistance is not required.

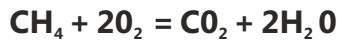

The calculation for air quantity solely depends on whether flared gas is low or high hydrocarbon gas (C/H) and the quantity of gas flared. As it is well known that when a hydrocarbon completely reacts with oxygen, it produces carbon dioxide and water which can be illustrated in eqn.

The eqn. above shows the reaction of Methane (CH₄) with oxygen for complete combustion, which further indicates that 2 moles of oxygen is required for complete combustion of 1 mole of Methane and hence in the same way as we move to higher hydrocarbon, the number of moles of oxygen required will increase.

Therefore, the amount of air calculated must account for the O₂ content in the atmospheric air as atmospheric air only contains 21% of oxygen.

A blower system should also be designed to produce the design airflow rate and velocity at the flare burner considering the air delivery system, the power of motor should be taken in excess by 15-20 % so as to accommodate the excess quantity of air needed at the time of flaring.

High Pressure flares: A high pressure flare does not require any utilities such as steam or air to promote smokeless

flaring, instead these flares utilize pressure energy available within the flare gas. It is used where smokeless burning is required and the relief gases are discharged from the flare burner at high velocity. The pressure of the relieving gas is converted into kinetic energy to promote air entrainment and mixing, which produces smokeless burning as in assisted flares. The advantage is that supplemental energy from steam or air is not required and hence can be used where there is no steam available or the cost of flare is to be minimized (As air assistance requires extra cost addition). As per API 521, the gauge pressure available at the flare tip should be at least 35 kPa to 140 kPa. As this much of pressure can create a high turbulence due to high exit velocity and hence air entrainment will be more, so it is necessary that the gas compositions flared must be rich in hydrocarbon fuel and should not have high inert gas content. For cases when the relief-gas contains sufficient hydrocarbon fuel, high-pressure flares have been shown to produce very high hydrocarbon-destruction efficiencies, exceeding 98 %.

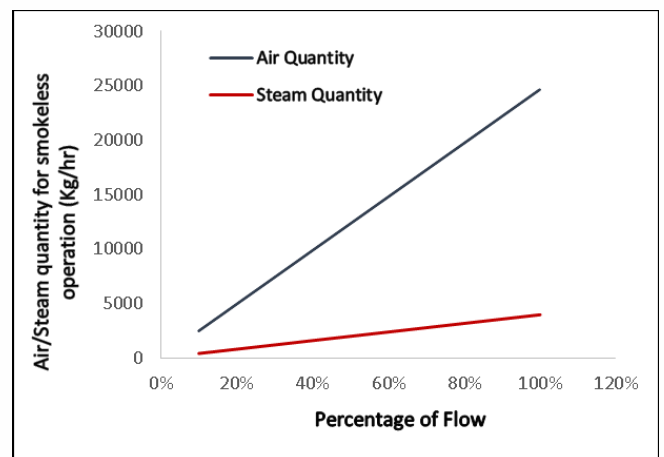

Fig. 3. Air/Steam quantity required for different percentage of flow for Butane (C₄H₁₀) for smokeless operation.

It can be clearly seen from the above graph that the air quantity is much higher than steam quantity for the same percentage of flow for smokeless operation.



A Guide on Smokeless Flaring: Air/Steam Assisted and High Pressure Flaring

By Project Engineering Business, ADOR Welding Limited.



III. CONCLUSION

- Smokeless burning is needed while flaring which needs different assistance like air, steam or high pressure of flare gas.
 - Hydrocarbon droplets entrained in the gas stream that are carried into the flame usually burn incompletely, can produce burning liquid droplets, form soot and decrease the smokeless capacity of the flare which can be minimized using Knockout drum or any liquid gas separator.
 - Typically, the smoking tendency is a function of the gas calorific value and of the bonding structure of hydrocarbons. The paraffinic series of hydrocarbons has the lowest tendency to produce smoke, whereas olefinic, diolefinic and aromatic series of hydrocarbons have much higher tendency to produce smoke.
 - The degree of smokeless is measured on Ringelmann scale (scale from 0 to 5) and is required while calculating the quantity of steam and air.
 - Steam injection is the most efficient way to reduce the smoke produced while flaring, but due to non-availability of steam, the air assisted flare is used.
 - The quantity of air required is approximately 1.2 times that of steam and the system is also expensive as per installation point of view.
 - High pressure flare technology can also suppress the smoke generation but it should be incorporated only when the calorific value of flare gas is very high. It can be used where steam is not available and the system needs low cost design.
 - High pressure flares can greatly reduce the flare flame radiation and also increases the combustion efficiency exceeding 98%.
- "A scale for determining the density of smoke (with full-page plate)". *Engineering News*. 38 (20): 307–308, 320. November 11, 1897. Retrieved 26 March 2019.
 - Dark smoke - an introduction to air pollution control (smoke) regulations (PDF). Hong Kong: Environment protection department, Hong Kong. Retrieved 31 August 2018.
 - Randolph, Karen; et al. (December 1993). "EPA 340/1-92-004 Visible Emissions Field Manual EPA Methods 9 and 22" (PDF). United States Environmental Protection Agency. Retrieved April 20, 2013.
 - "A scale for determining the density of smoke (with full-page plate)". *Engineering News*. 38 (20): 307–308, 320. November 11, 1897. Retrieved 26 March 2019.
 - API standard 537, second edition, (December 2008): Flare details for general refinery and petrochemical service.
 - U.S. EPA, Compilation of Air Pollutant Emissions Factors, Vol. 1, Stationary Point and Area Sources, AP42, 4th Edition, 1985 and supplement F: Section 11.5, 9/91, Industrial Flares.
 - POHL, J.H., Combustion Efficiency of Flares, U.S. Environmental Protection Agency, Research Triangle Park, N.C., 1985.
 - ROMANO, R.R., Control Emissions with Flare Efficiency, Hydrocarbon Processing, Oct. 1983.
 - BS2742, Notes on the use of the Ringelmann and miniature smoke charts, British Standards Institution, London.
 - D. E. Loudon, "Requirements for Safe Discharge of Hydrocarbon to Atmosphere," API Refining Proceedings, 1963, Volume 43, API, Washington, DC, pp. 418–433.
 - W. R. Smith, "Eliminate Air-Polluting Smoke," Petroleum Processing, June 1954, pp. 887–881.

IV. REFERENCE

- API Standard 521, Sixth edition, (January 2014): Pressure relieving and depressurizing systems.
- Hughes, Glyn (2010). "The Ringelmann smoke chart" (PDF). SOLIFTEC The Solid Fuel Technology Institute. Retrieved 31 August 2018.

